



RE: Ball Joint and Ball Joint Kits

Thank you for your enquiry into AIRTIGHT SOLUTIONS range of Modular Ducting, Dust Collectors and quality Flexible Hoses.

Our Ball Joints are of unmatched quality in the industry and stocked in Sydney and Brisbane warehouses. Typical applications for Ball Joints include CNC machines and other applications where expensive flexible hoses may wear out prematurely. Ball joints will relieve the stress on the hose at the collection point, leading to greatly increased lifespan of the hose.

Stress on the hose can come from both the extensions and angle of the hose (typical on long bed CNC’s or in low roof height scenarios). Other causes of reduced lifespan are from the material travelling through the hoses and hitting the side wall at the collection point.

Airtight Ball Joints will typically alleviate both situations.

BALL JOINT

Ø	PART NO.	ENDS	LENGTH (L)	GAUGE	GALV. PRICE	WEIGHT (GALV)
3"	3209-0300	QF	8.00	20	Ask for quotation-	1.50
4"	3209-0400	QF	9.50	20		2.10
5"	3209-0500	QF	10.75	20	Quantity dependent	2.75
6"	3209-0600	QF	11.75	20		3.85
7"	3209-0700	QF	10.75	20		4.25
8"	3209-0800	QF	14.00	18		5.00
9"	3209-0900	QF	15.00	18		7.45
10"	3209-1000	QF	14.25	18		8.95
12"	3209-1200	QF	15.25	16	9.25	
14"	3209-1400	QF	17.50	14	15.70	

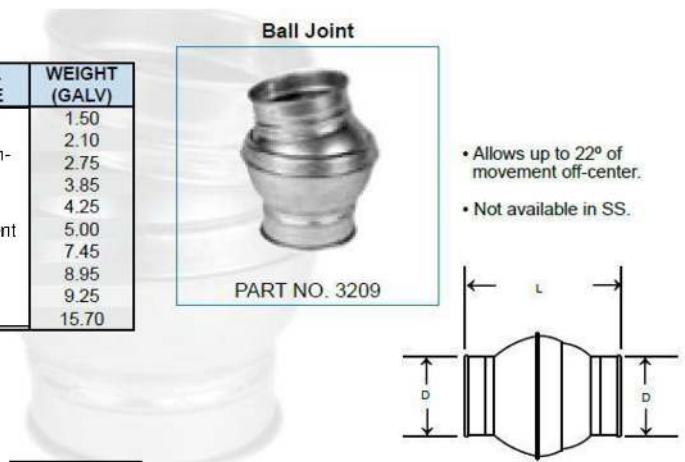

Example of typical Ball Joint Kit below:



If you have any questions, please don't hesitate to contact our offices or website as below

